



GENERAL FEATURES

- Rack size **50x50 cm**
- Gross weight: 77 Kg
- Washing cycles / racks/hour : 60"-120"-180"/
60-30-20
- Top and bottom wash/rinse arms
- Wash pump 550 W with Soft-Start function
- Boiler capacity 5 liters
- Tank capacity 27 liters
- Boiler heating element 3,0/4,5 Kw
- Tank heating element 3,0/4,5 Kw
- Water consumption per cycle 3 liters
- Electronic controls
- Display for boiler and tank temperatures
- Extractable control panel
- Useful washing height: 330 mm
- Magnetic door microswitch
- Automatic water filling
- Adjustable rinse-aid dispenser
- Hot rinse
- Thermostop function
- Anti back-flow valve
- Automatic end-of-day self cleaning water tank

FILTRATION

- S/S single filter for wash pump and drain, easily removable
- S/s filters for pre-filtering of tank water

BODY

- In stainless steel AISI 304
- Insulated double skinned body and door
- Door handle in s/s
- Preformed wash tank
- Preformed rack guides
- Door with springs closing
- Wash/rinse arms in s/s, easily removable
- Boiler in s/s AISI 304
- Overflow in s/s

EQUIPMENT

- 1 glass rack 50x50 cm
- 1 plates rack 50x50 cm (12/18 plates)
- 1 cutlery small basket
- 1 inlet hose (length 2 mt)
- 1 drain hose (length 2,5 mt)

Extra

- Electric detergent dispenser
- Drain pump
- S/S Surface filters

ACCESSORIES FOR THE WATER TREATMENT

- External water softener
- Osmose unit

INSTALLATION

- Use the screws of the feet and a spirit level to ensure that the machine is levelled

MAIN POWER SUPPLY

- The voltage of main power supply must be compatible with the rated voltage
- The machine must be connected to a suitable earth (ground) system
- Connect the machine power socket to the multi-pole wall switch provided

WATER SUPPLY CONNECTION

- A water softener must be installed if the water is hard
- The water pressure must be between 0.2MPa (2 bar), and, 0.5MPa (5 bar)
- The temperature of the water-supply must be between 10°C to 50°C

TECHNICAL SPECIFICATIONS

- Voltage: 230V /400V3N ~ 50 Hz
- Total power : **3,6/5.3 kW**
- Amperage: **16/10A**
- Power cord supply size:**3x2,5mmq / 5x2.5 mmq**

LK 50.34 E

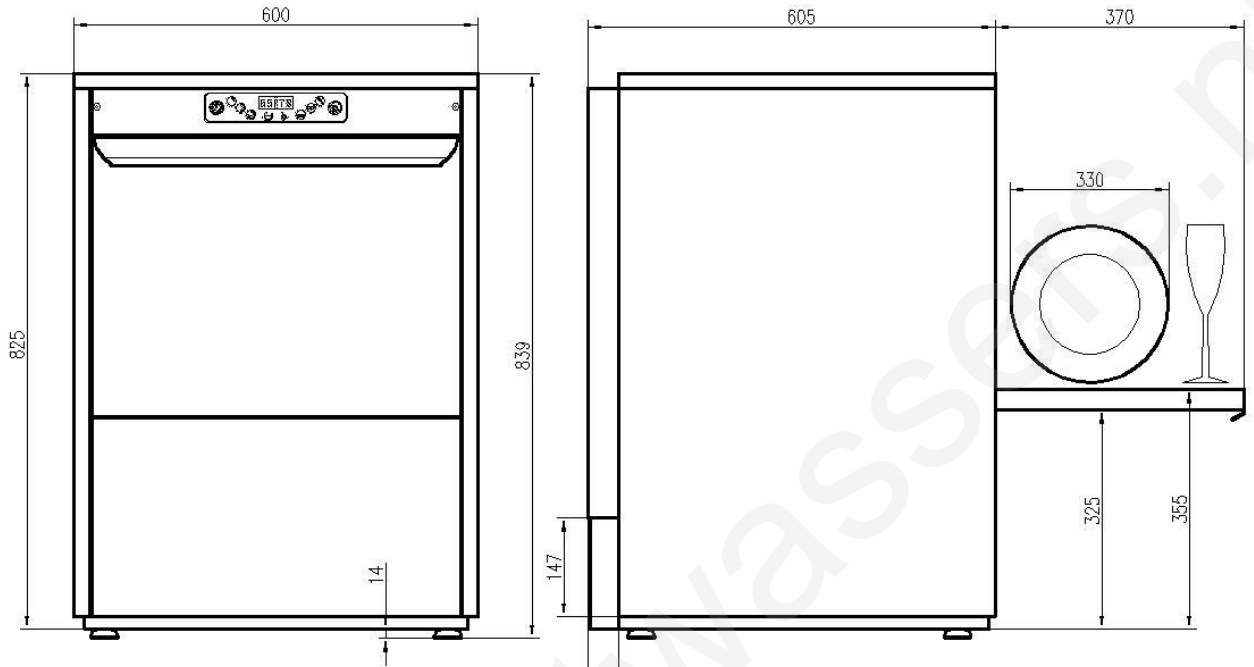

(*)= VANO DI PASSAGGIO TUBI DI CARICO E SCARICO ACQUA
FILO EQUIPOTENZIALE

(*)= PASSAGE FOR WATER OUTLET AND INLET PIPE AND
UNIPOTENTIAL WIRE

(*)= OUVERTURE DE PASSAGE TUYAUX DE VIDANGE, ALIMENTATION EAU
ET CONNEXION EQUIPOTENTIELLE.

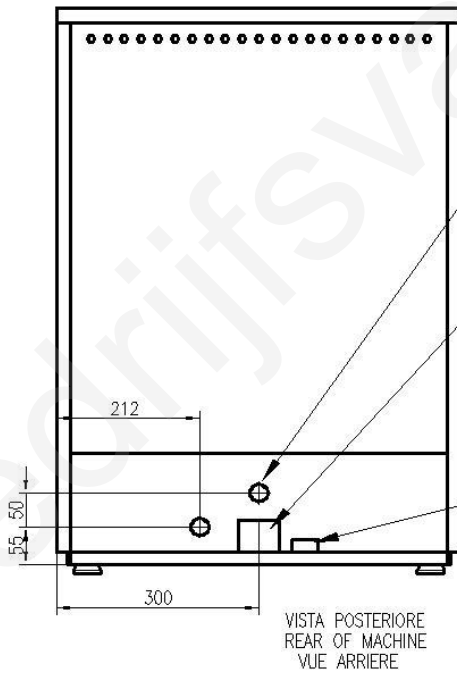

USCITA CAVO DI ALIMENTAZIONE
EXIT POWER CORD SUPPLY
OUVERTURE DE PASSAGE CABLE D'ALIMENTATION

TUBO DI SCARICO Ø INT. mm.28 LUNGHEZZA mm. 2000
EXIT WATER OUTLET PIPE INT. Ø 28 mm. L=mm. 2000.
TUYAU DE VIDANGE Ø INT. 28 mm. L=mm. 2000.

CANNA DI CARICO CON ATTACCO G 3/4" LUNGHEZZA mm. 2000.
WATER INLET PIPE CONNECTION G 3/4" L=mm 2000.
TUYAU D'ALIMENTATION EAU AVEC CONNEXION G 3/4" L=mm 2000.

VISTA POSTERIORE
REAR OF MACHINE
VUE ARRIERE

	Min 10°C-MAX 50°C Min 10°C-MAX 25°C with ENERGY RECOVERY
	200±500kPa(2±5 Bar) 100±500kPa(1±5 Bar) with ATMOSPHERIC BOILER
	HARDNESS 5±20f-2.8±11'd