



GENERAL FEATURES

- S/S Rack **126x90 cm**
- Total weight: 330 Kg.
- Washing cycles / racks/hour : 2'-3'-6'-9'/30-20-10-7
- No.2 pcs. 3-way s/s upper and lower rotating wash arms +no. 2 pcs. lateral washing fixed tubes
- No. 2 pcs. independent rotating upper and lower rinse arms
- No. 2 wash pumps: 2.35 kW
- Boiler capacity: 17 lt.
- Tank capacity: 100 lt.
- Boiler heating element: 9 kW
- Tank heating element: 9 kW
- Water quantity per cycle: 7 lt.
- Electronic controls
- Display for boiler and tank water temperatures
- Useful washing height: 800 mm
- Door microswitch
- Automatic filling of water, direct into the tank
- Hot rinse
- No. 2 rinse booster pumps
- Break Tank
- Atmospheric boiler
- Thermostop function
- Automatic end-of-day self-cleaning cycle of washing tank
- Vertical self-cleaning washing pumps

WATER FILTRATION

- Pre-filtering of tank water made of no.1 s/s mesh basket filter
- S/S inle wash pump filter, easily removable

BODY

- Body in stainless steel
- Double skinned body and door, insulated
- S/S door handle
- Preformed wash tank in s/s AISI 316
- S/S removable upper and lower wash/rinse arms for easy cleaning
- Boiler in s/s AISI 316

EQUIPMENT

- 1 s/s rack on wheels 126x80 cm
- 1 water inlet hose (1,5 mt length)
- 1 water drain hose (2 mt length)

Extra's

- Electric detergent dispenser
- Drain pump

Options

- External Water softener
- Electric rinse-aid dispenser

INSTALLATION

- Level the machine acting on the adjustable feet

ELECTRIC CONNECTION

- The mains voltage must be the one indicated on the serial no. label
- The machine must be connected to a suitable earthing system
- Connect the power plug to a suitable omnipolar wall switch

WATER CONNECTION

- Connect a water softener in case of hard water
- The water pressure must be between 0.1MPa (1 bar) and 5MPa (5bar).
- The water temperature must be between 10 and 50°C

TECHNICAL SPECIFICATIONS

- Voltage: **400V3N ~50 Hz**
- Total power : **14 kW**
- Amperage: **25 A**
- Power cord supply size. : **5 x 4 mmq**

UK 125-80 E PRS

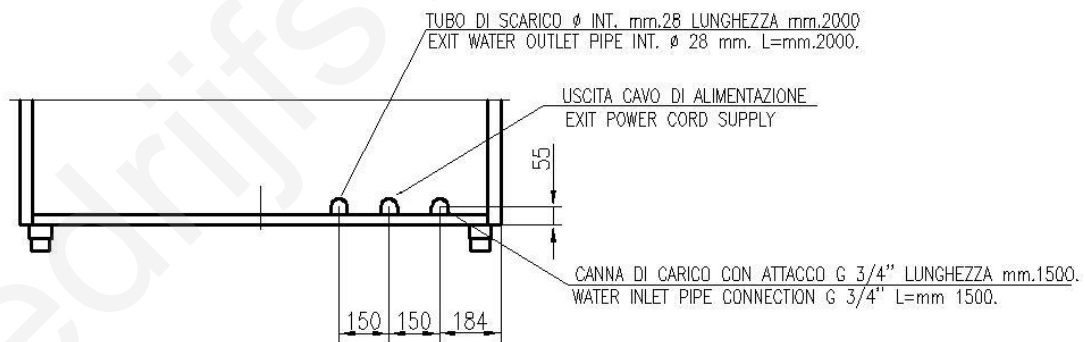
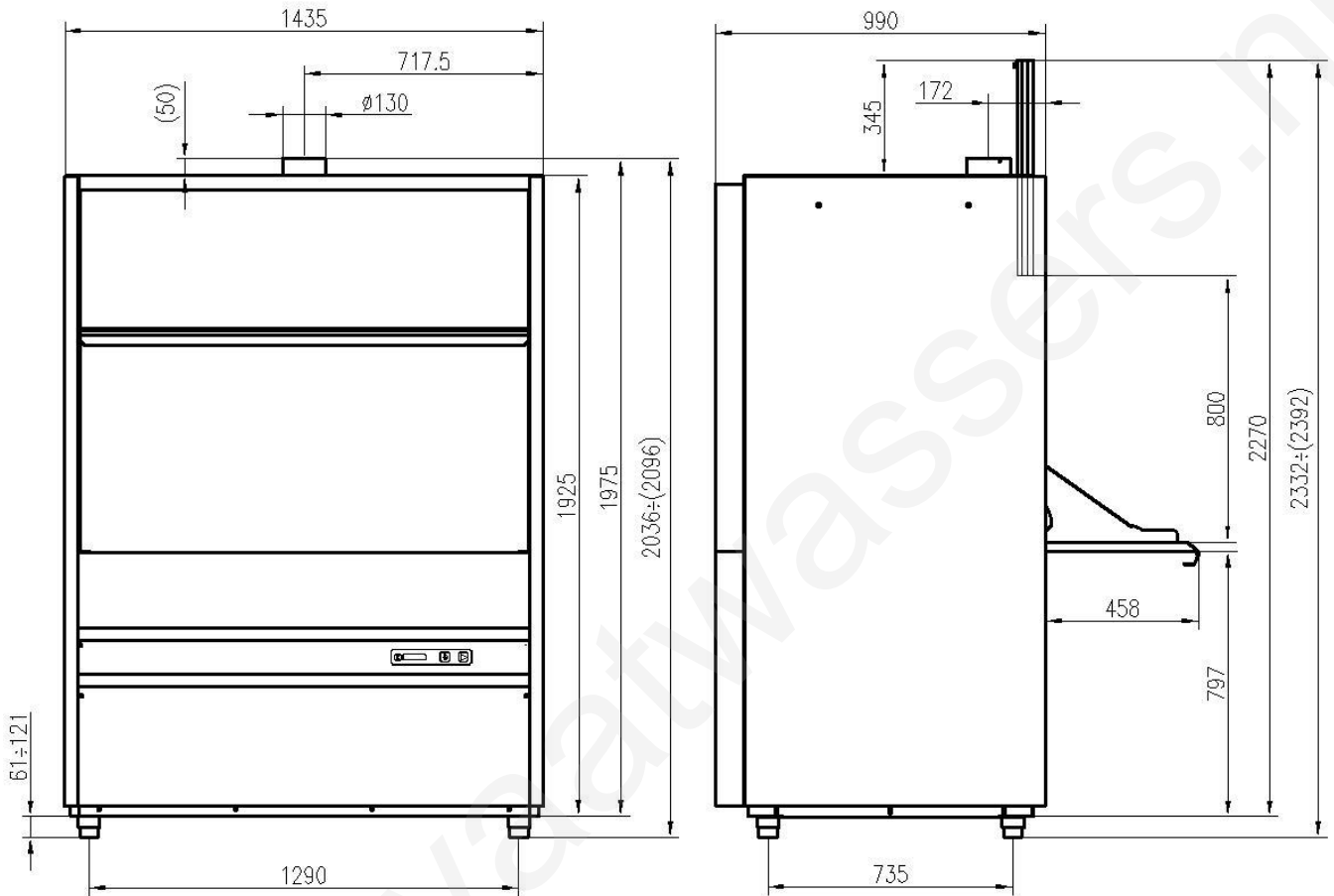

VISTA POSTERIORE
REAR OF MACHINE

	Min 10°C-MAX 50°C
	200÷500kPa(2÷5 Bar) 100÷500kPa(1÷5 Bar) with ATMOSPHERIC BOILER
	HARDNESS 5÷20°f-2.8÷11°d